

# ORIGAMI BIRD

AS004

---

pattern designed by



AMARAR  
STUDIO

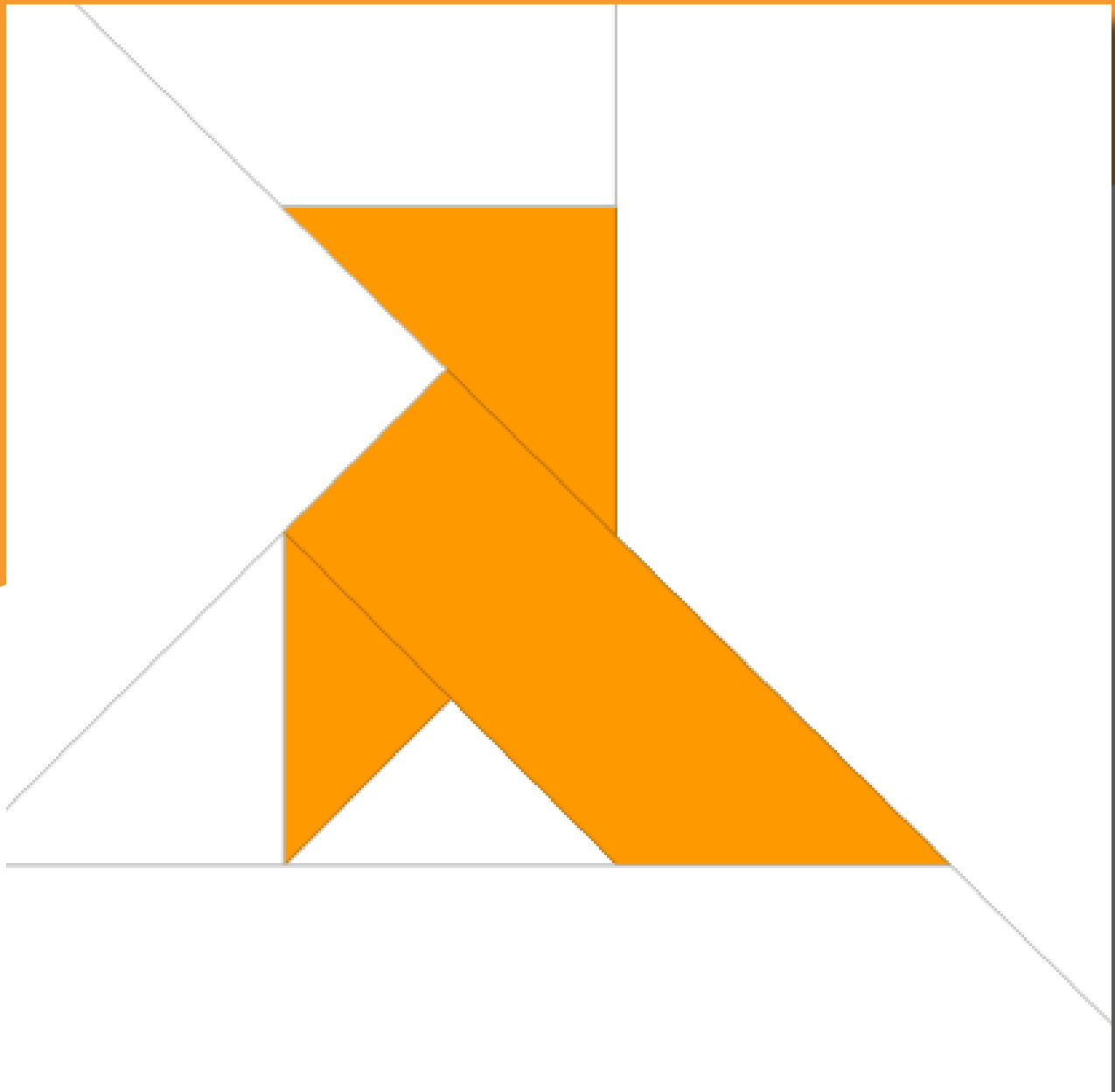

---

Foundation Paper Piecing  
9" square  
Beginner Skill Level

Learn the Foundation Paper Piecing technique with this easy, fun and quick pattern. And you can use the block to create a pillow, a wall hanging or a pillow with the bird shape!

Check the [Foundation Paper Piecing Tutorial](#) by Amaran Studio and follow all the steps. There are several ways to make the foundation paper piecing. This tutorial shows the way I think is more easy and fast. (<https://amararstudio.com/foundation-paper-piecing-tutorial/>)

You are invited to join the [Amarar Studio Club on Facebook](#) where you can also check the tutorial, share your Amaran Studio patterns projects and meet quilters all over the world. I will be happy to help and assist you with the FPP technique or any other quilting questions. See you there!

Be sure to share your version of the [#origamibirdblock](#) on Instagram!

### Finished Size

Block  
9" x 9" / 23 x 23 cm

### Skill Level

Beginner

### Getting Started

Please read the entire pattern before starting your “Origami Bird” block.

To print the templates, set the printer to “actual size” and not to “fit to page”. Check the 1” square to ensure the right final quilt size.

Pattern available in [Quiltink](#) to be color planned in a digital, fast and fun way!

### Supplies / Tools

- Paper and printer
- Rotary cutter and cutting mat
  - Ruler
  - Scissors
- Sewing machine
  - Thread
  - Iron
- Fabrics (check back cover)

## Index

1. Assembly Instructions .....	2
2. Sections Diagram .....	3
3. Size and Pattern Scaling .....	4
4. Terms of Use .....	4
5. Section Templates .....	5
6. Cutting Templates .....	8
7. Coloring Sheet .....	12

# Assembly Instructions

Print all the section templates. + Cut them with the 1/4" (0.64 cm) seam allowance included to join them.

Pattern structure*	
Sections	Units
2	9

\* Check the next page for more details.

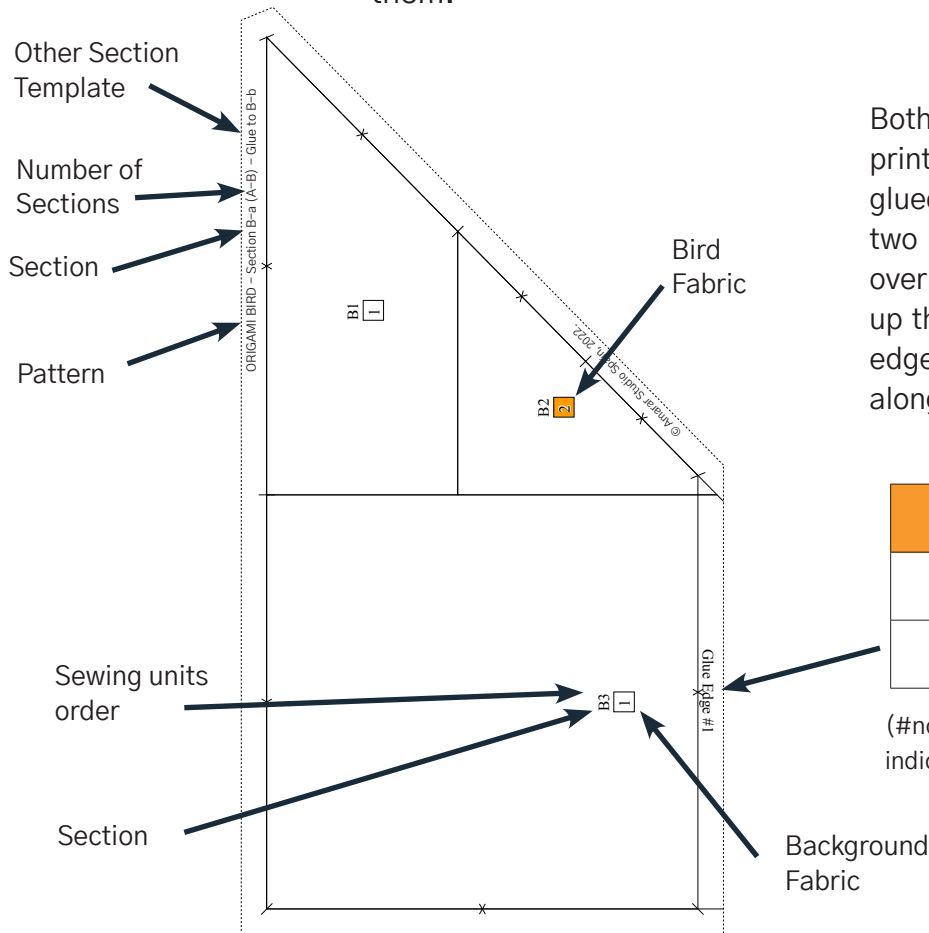

Both pattern section templates are printed in 2 pieces which must be glued or taped. To properly align the two parts of those sections or units, overlap seam allowances and match up the solid lines of the noted "glue edge" between the pieces together along designated edges.

Sections
A = Aa + Ab (1)
B = Ba + Bb (2)

(#no.): It's the "Glue Edge #no." indicated in the templates.

**Choose and cut the fabrics.**

You can pre-cut the fabrics with the cutting templates which include a margin of 1/2" (1.3 cm). The cutting templates are MIRRORED, so place them to the fabric wrong side, to cut the pieces.

**Sew every fabric** to its section following the sewing units order.

The Section templates are mirrored. Place the fabrics on the non-printed side of the paper to sewn them, with right side up.

+ **Join the sections** according to the order established below and the sections diagram shown in the next page.

1. Join A to B                      A + B

**Full block size** = 9 1/2" x 9 1/2" (24.3 x 24.3 cm).

It's 1/4" (1.3 cm) bigger on every side than the final size. You can cut this allowance fabric to adjust your sides to the final size of 9" x 9" (23 x 23 cm) or leave it to join the block to other fabrics or blocks.

## Sections Diagram

Use these table and diagram to see the sections and units that make up the pattern and to know how to place the sections when assembling each other.

This image is reversed. It is how you will see the section templates, by the printed side of the paper, when you are joining them.

Sections (2)	A	B
Units (9)	6	3

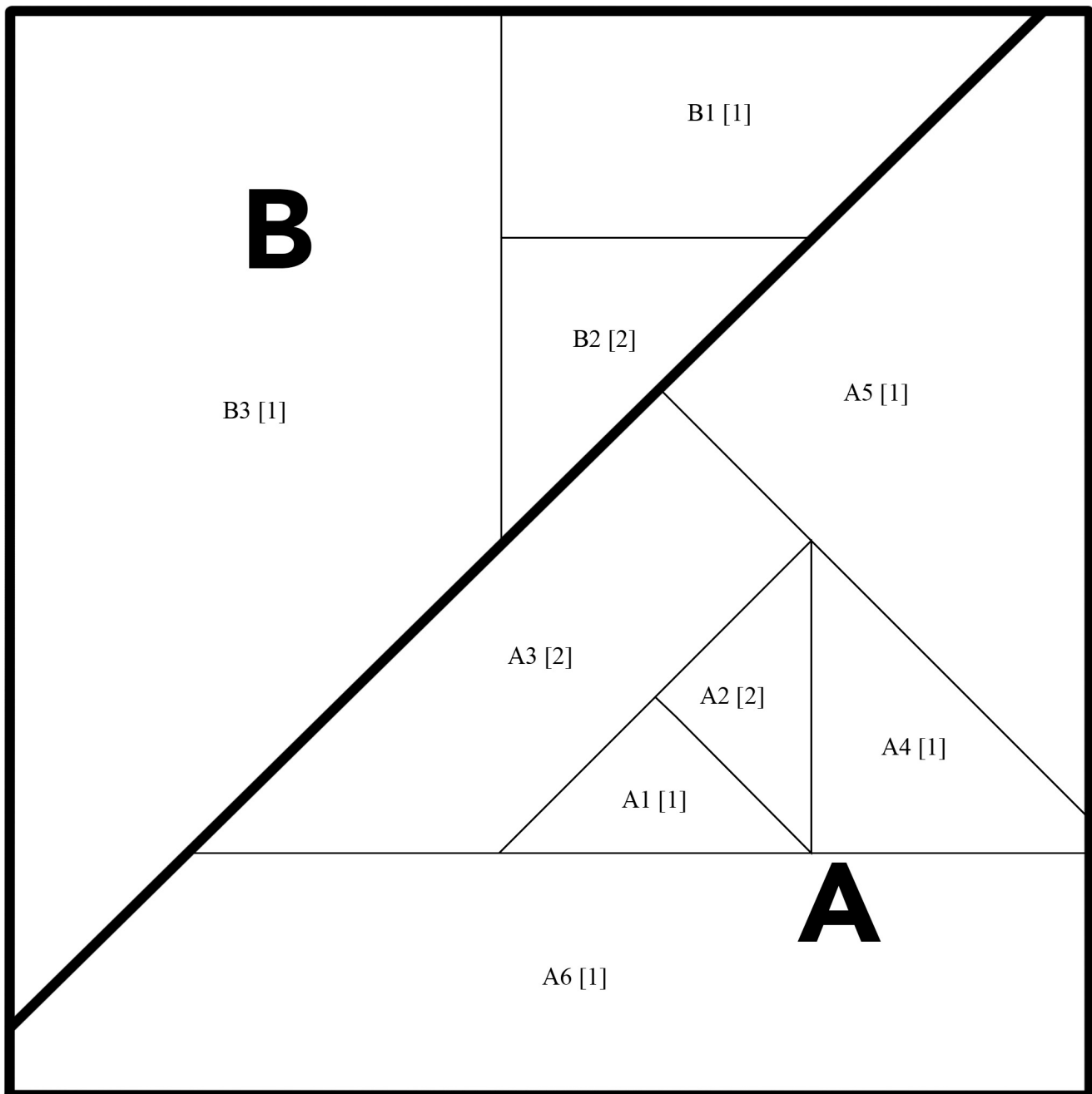

## Sizes and Pattern Scaling

If you print the templates of the pattern at 100%, you will obtain a 9” (23 cm) square block.

If you want another size, you can calculate, with the next formula, the % you have to scale the printing depending on your desired size (remember the 1/4” (0.64 cm) seam allowance will be scaled too):

$$\% \text{ of scaling} = \frac{\text{Desired size (in)} \times 100}{9}$$

Pattern scaling examples:

Desired size	% of scaling
4 1/2”	50 %
12”	133.33 %
15”	166.67 %

Any questions? Do not hesitate to email me: [amararstudio@gmail.com](mailto:amararstudio@gmail.com)

## Terms of Use

This document is the version 1 of the Origami Bird pattern, AS004. You can download the updates by downloading again the pattern from the Foundation Paper Piecing Tutorial page at [www.amararstudio.com](http://www.amararstudio.com):

- Check for updates: <https://www.amararstudio.com/pattern-updates>
- Tutorial page: <https://amararstudio.com/foundation-paper-piecing-tutorial/>

Do not copy or redistribute this pattern in any form, it’s only for personal use. You may sell handmade items made from this pattern, sewn by you on a small scale, but mass production of any sort is not allowed. If you sell or show a picture of your made item, the credit for the pattern must be given to Amaran Studio ([@amararstudio](https://twitter.com/amararstudio)).

Copyright © Catalina Barceló Maimó. Spain, 2022. All rights reserved.

# Section Templates

1. Cut the templates for the sections with the 1/4" (0.64 cm) margin included to join them.
2. Glue the templates where it states "Glue Edge # no.".
3. Before cutting the templates, print this page and check the 1" scale block to get the right finished size. If the block is different from 1", check your printer's scale settings.
4. Sew the fabrics to every section and join the sections according to instructions on page 2.

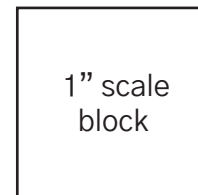
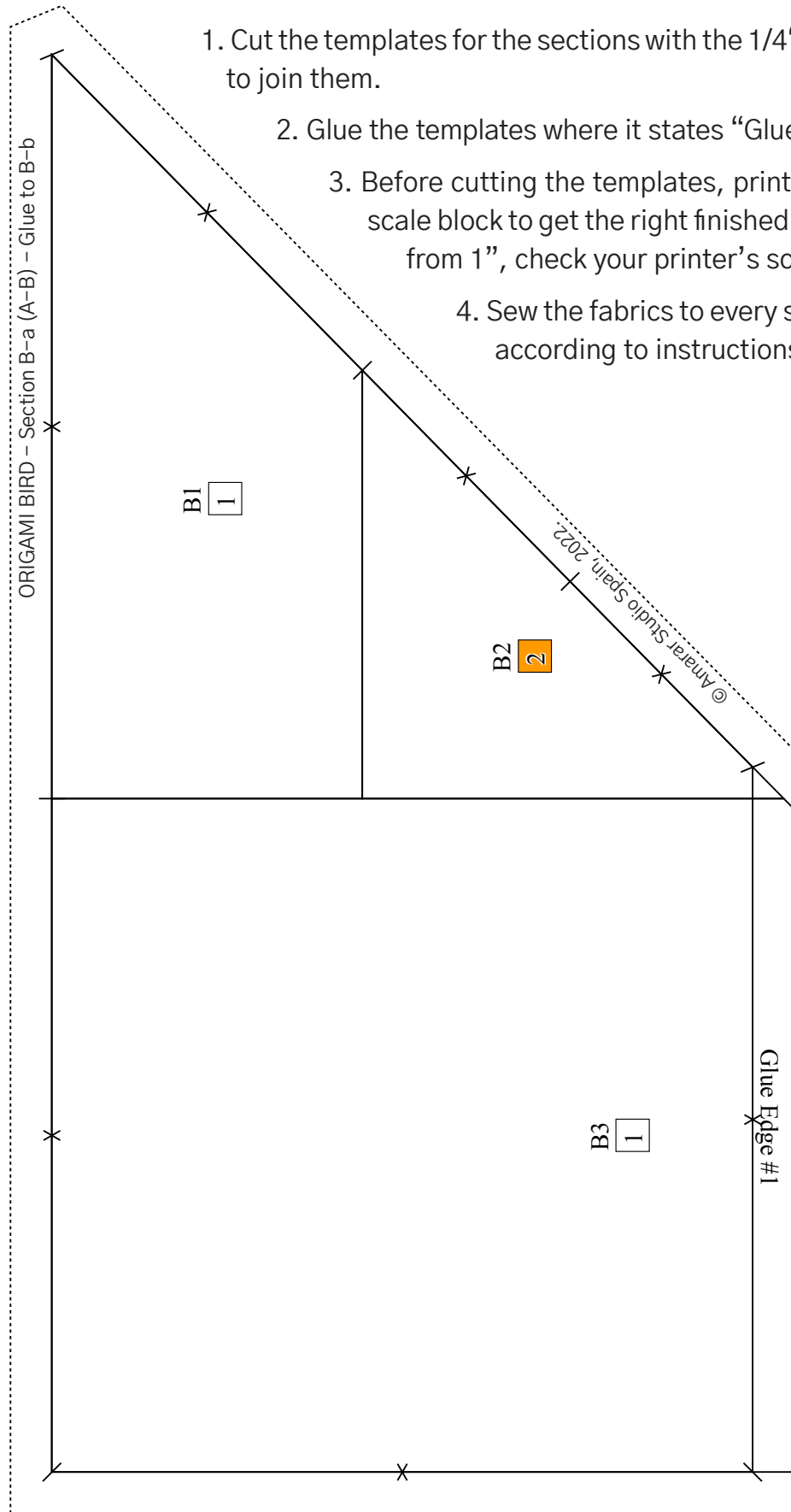

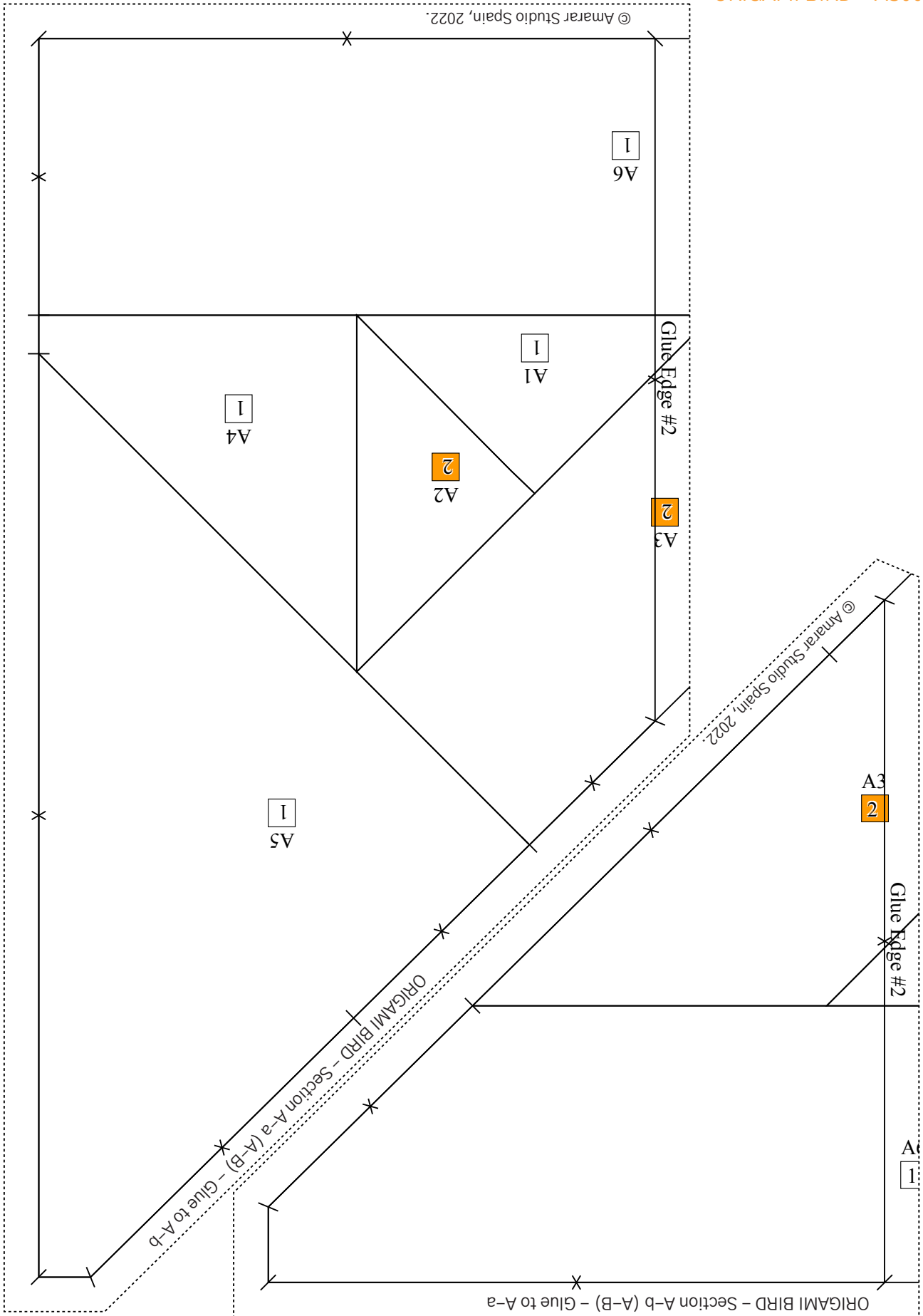

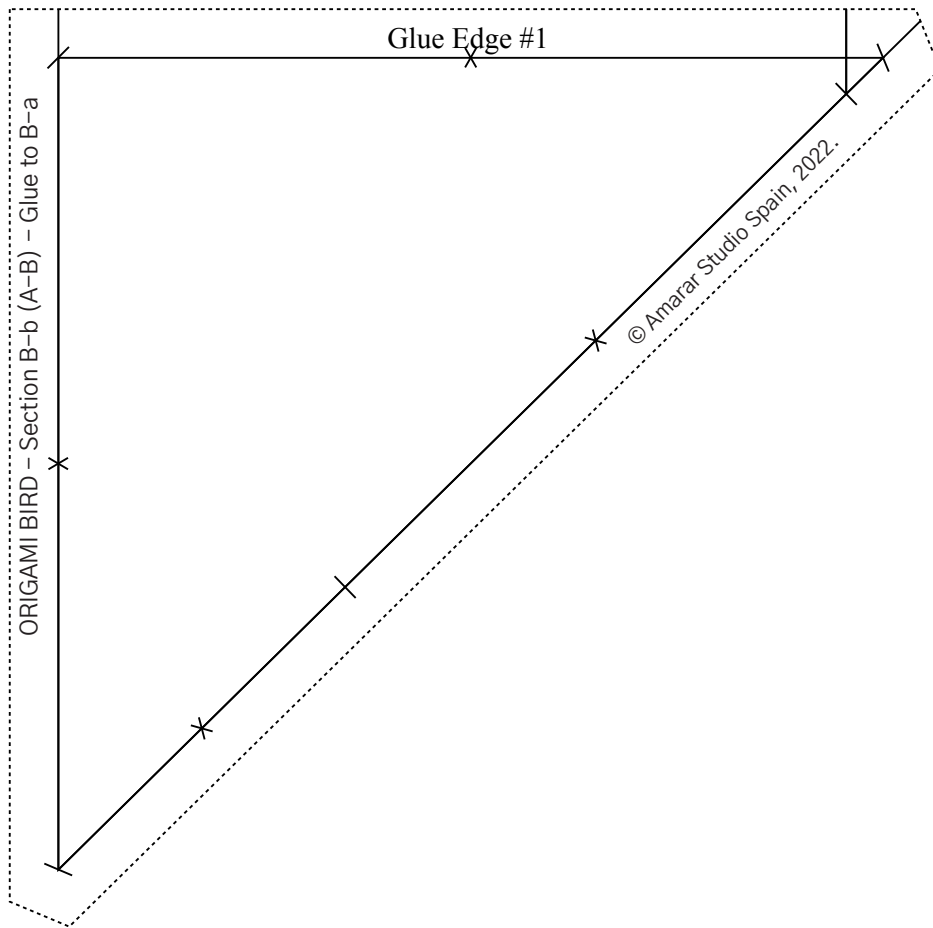



# Cutting Templates

1. You can use these templates to cut the fabrics as the same shape of the pattern units.
2. These cutting templates have 1/2” (1.3 cm) allowance.
3. Before cutting these templates, check the 1” scale block to get the right finished size. If the block is different from 1”, check your printer’s scale settings.
4. The cutting templates are mirrored, so, if you use them, you must place the templates on the wrong side of the fabrics to cut the pieces.

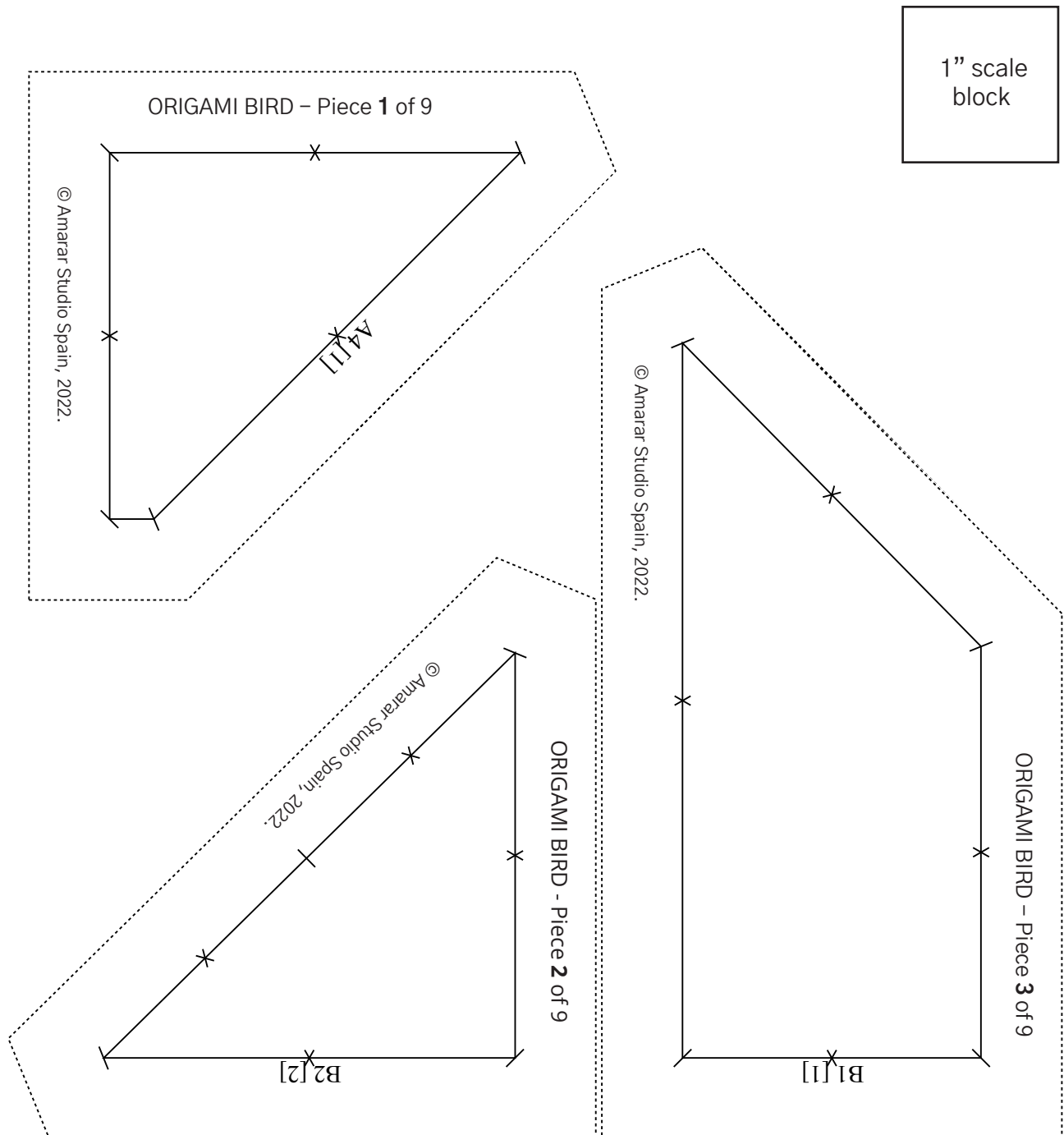

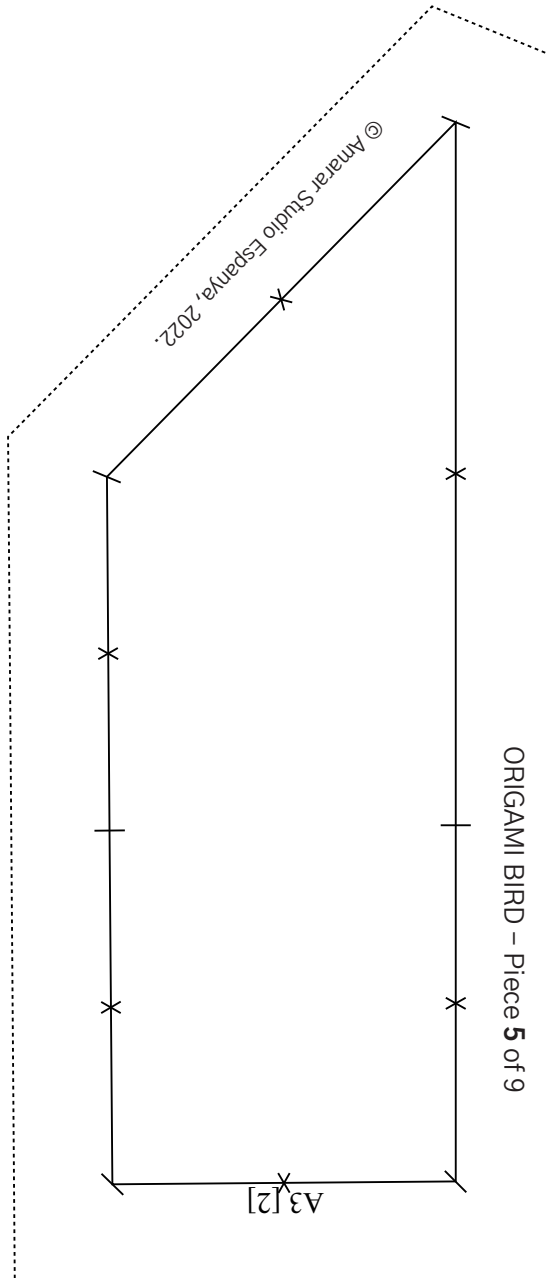
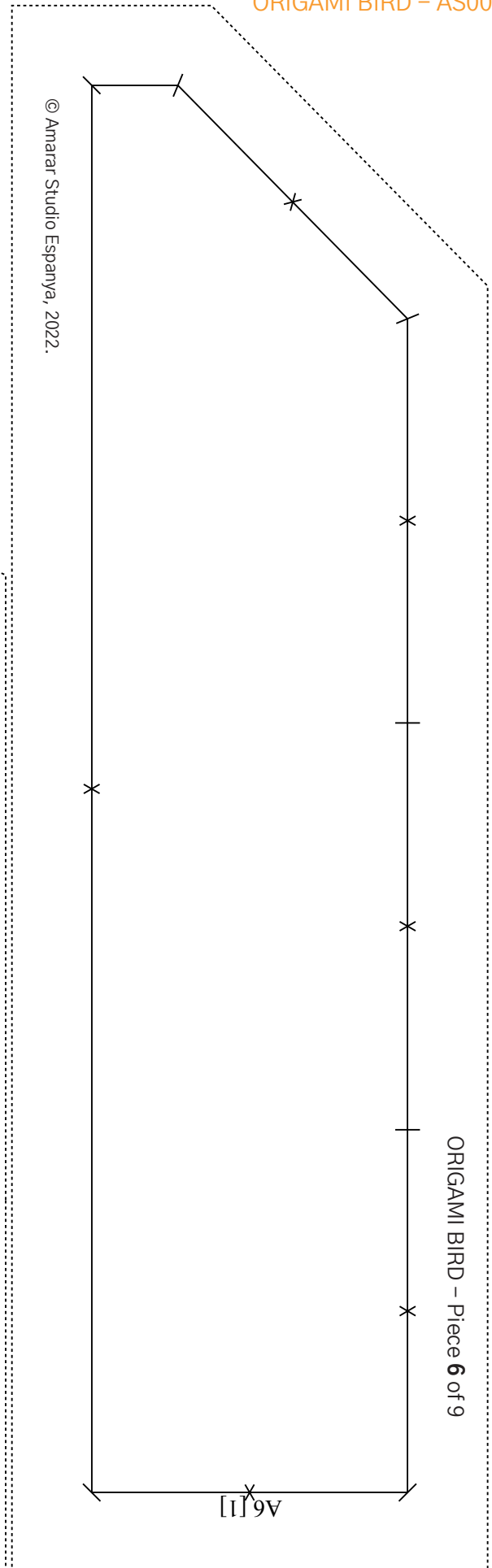
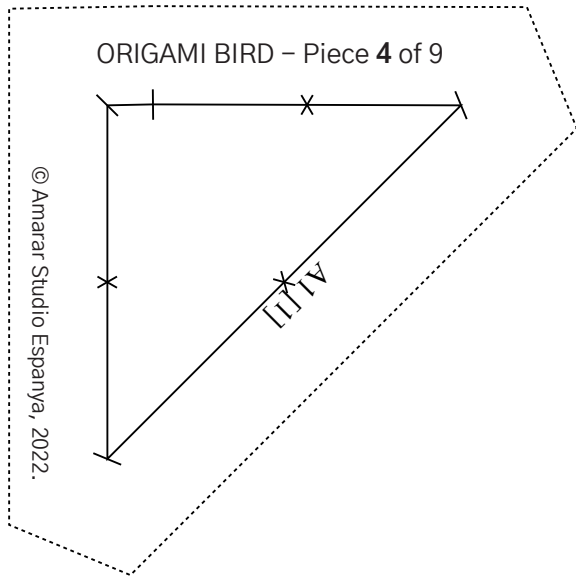

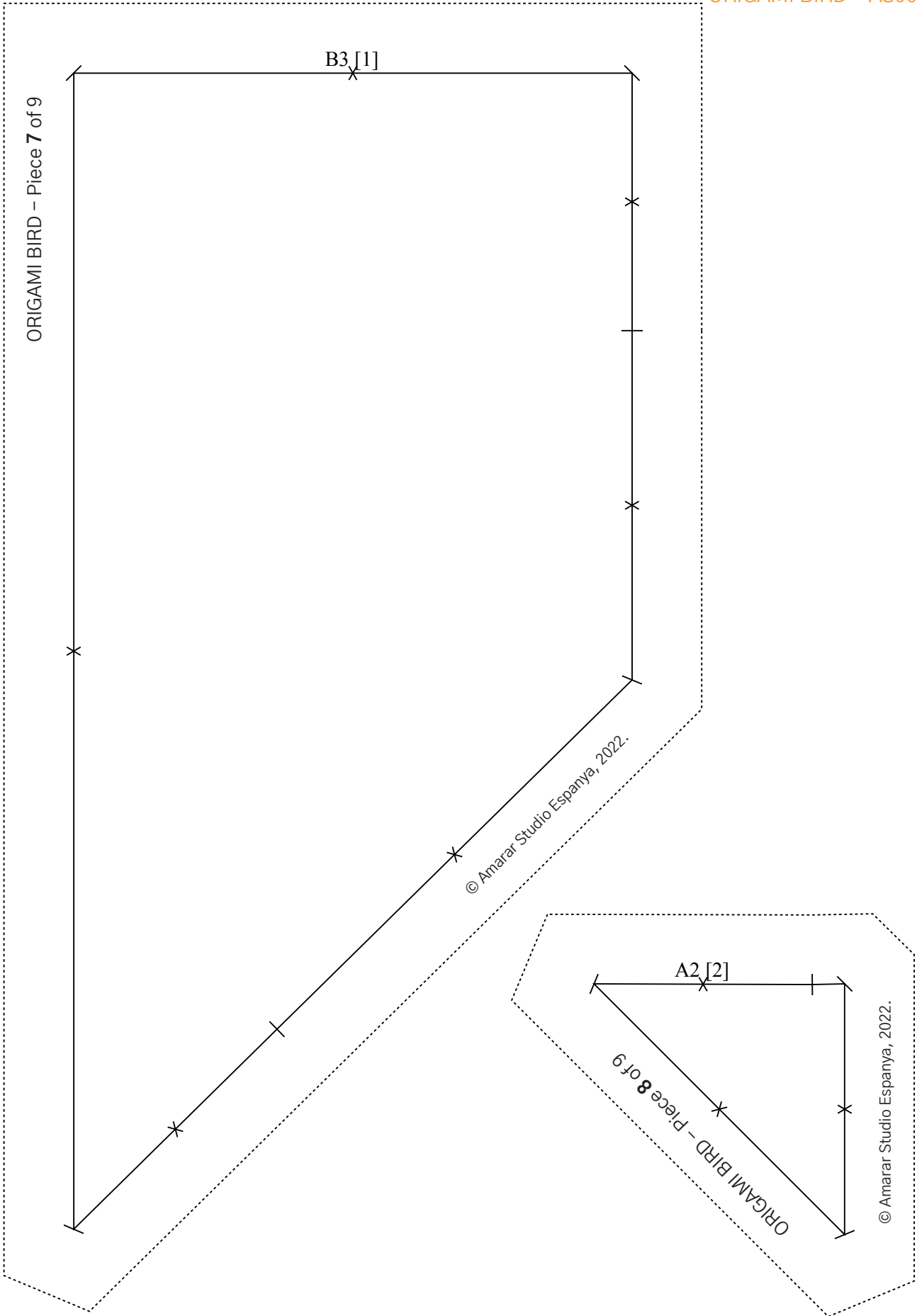

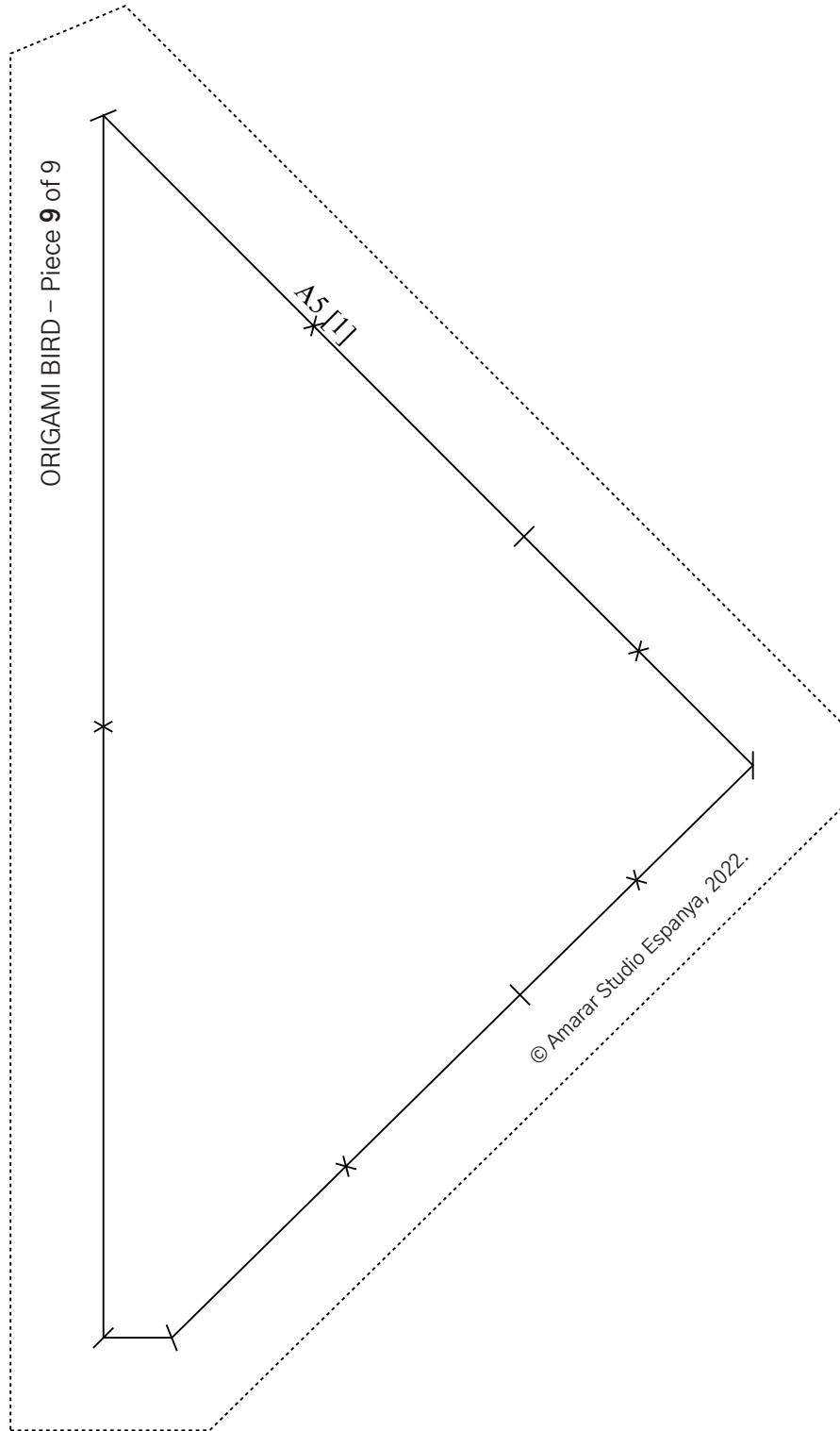

## Coloring Sheet

Here is the pattern drawing to color and choose the fabrics.

On the Section Templates, color number 1 (white) corresponds to the Background fabric and color number 2 (orange) corresponds to the Bird fabric. You can plan your project with 2 colors or as you wish.

This image is not reversed, so it's how design will be seen by the side of the fabrics after finishing the assembly of the entire pattern. It's important to be aware that the pattern section templates and the pattern diagram with sections are reversed, so their coloring has to be reversed to this image.

Remember this pattern is available in [QuiltInk](#) for digital coloring.

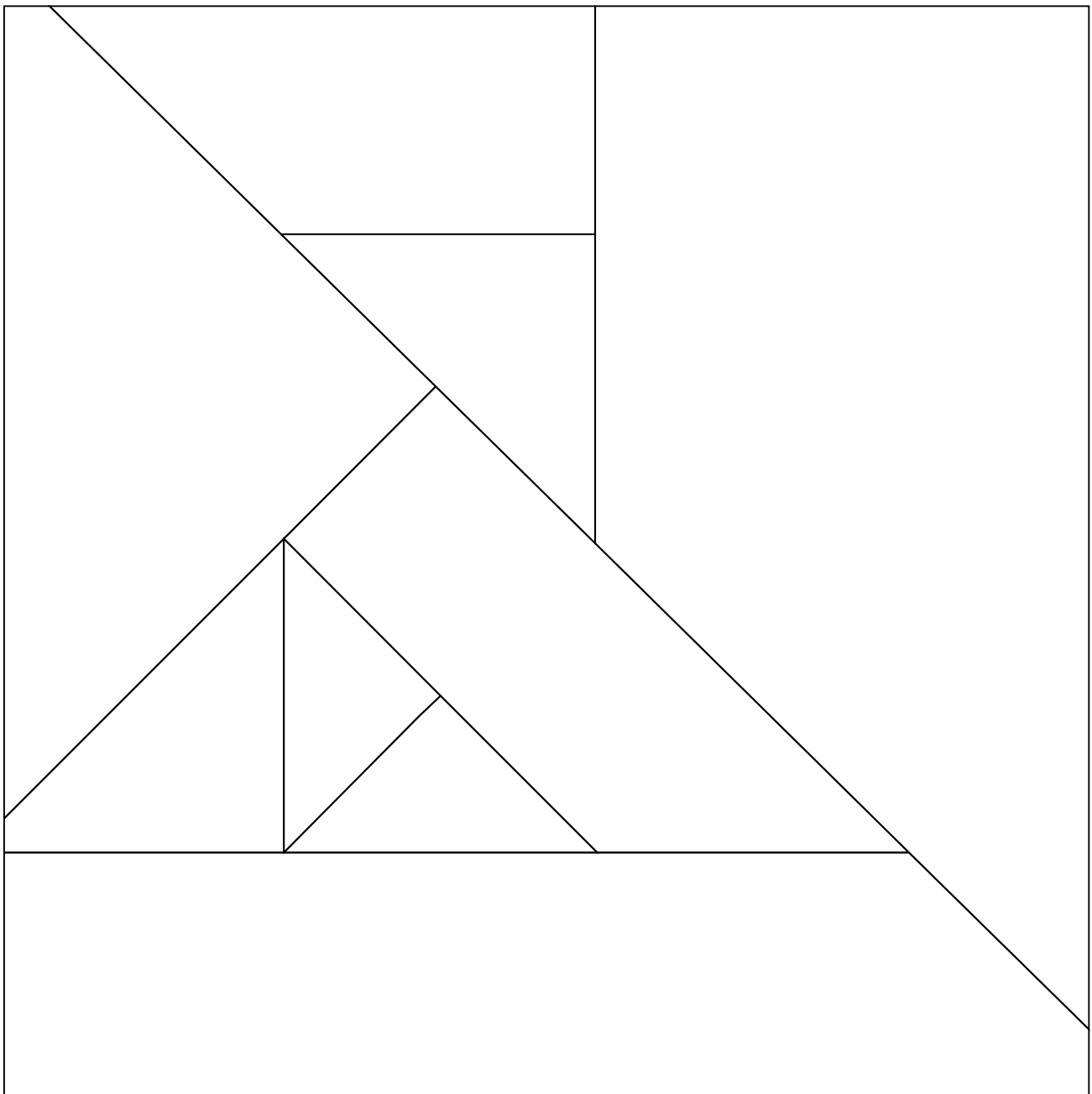

# ORIGAMI BIRD

## FPP Pattern / Version 1 PDF Downloadable

Learn the Foundation Paper Piecing technique with this easy, fun and quick pattern, by following our [Foundation Paper Piecing Tutorial](#) and enjoy this amazing technique!

### What's inside

- Assembly Instructions
  - Sections Diagram
- Size and Pattern Scaling
  - Terms of Use
  - Section Templates
  - Cutting templates
  - Coloring Sheet

Pattern Features	
<b>Design</b>	Figurative – Origami Bird
<b>Technique</b>	Foundation Paper Piecing
<b>Size</b>	9” square (23 cm square)
Fabric Requirements*	
<b>Bird</b>	10” x 10” (20 x 20 cm) or scraps
<b>Background</b>	1 Fat Eighth (50 x 25 cm)

\*: based on unit templates with 1/2” margin plus some more inches. Also, listed the best fitting precut fabric. Depending on your personal method of paper piece you may require a little bit more or less fabric.

Color this pattern  
with







Please share your project and  
search for inspiration using:

[#origamibirdblock](#)  
[#amararstudiopatterns](#)  
[#amararcreacionspatterns](#)  
[@amararstudio](#)

Pattern AS004 designed by:



 [www.amararstudio.com](http://www.amararstudio.com)  
 [amararstudio@gmail.com](mailto:amararstudio@gmail.com)  
 [@amararstudio](https://www.instagram.com/amararstudio)  
 [@amararstudio](https://www.facebook.com/amararstudio)  
 [Amarar Studio Club](#)

Copyright © Catalina Barceló Maimó, Spain, 2022. All rights reserved.  
Do not copy or redistribute this pattern in any form, it's for personal use. You may sell handmade items made from this pattern sewn by you on a small scale, but mass production of any sort is not allowed. If you sell or show a picture of your made item, the credit for the pattern must be given to Amaran Studio.